

FILTERING EQUIPMENT

FILTER SERIES



JX FILTARTION (CHINA) CO.,LTD

Mobile / Whatsapp: +86 159 2865 0174

TEL / FAX: +86-028-8600 8791

Website: www.filtrationchina.com

E-mail: sales@filtrationchina.com

Address: Fumin Road, Tianfu New Area,
Chengdu, Sichuan, China

OUR COMPANY

We are specialized in design, manufacture and sale of various filtration equipment, as well as comprehensive filtration solutions and projects.





With top class R&D personnel, experienced workers and high qualified sales team, we are all devoting to provide best products for our clients. With many year's unremitting efforts, we have earned trust among our clients. Now, our products have been sold to Canada, Spain, Norway, Chile, Nepal, Russia, Indonesia, Ecuador and etc.



OUR PRODUCT

- Media Filter
- Precision Filter
- Bag Filter Series
- Solid And Liquid Separator
- Diatomite Filter
- Sieve Bend Screen Filter
- Self-cleaning Filter Series
- Rotary Drum Filter Series

OUR SERVICE

-  Filtration consulting and solutions department
-  Fast after sale service and experienced service engineer
-  Periodic follow up service
-  Quick supply system of consumables and spare parts

MEDIA FILTER



Media filter is generally called deep bed filter. Water flow through the filter layer filled with filter media with a certain level of thickness and particle size to reach the filter effect.

The media can be quartz sand, sand gravel, activated carbon or other granular material. The level of filtration depends on the diameter of the particles that comprise the filter bed and the flow rate of the water.

- 1. Inlet; 2. Water
- 3. Sand Bed (Filtration Layer)
- 4. Outlet;
- 5. Filtration Nozzles
- 6. Checking Holes
- 7. Sand Feeding Inlet



WORKING PRINCIPLE

After the water enters from the water inlet and flows through the filter layer, the suspended impurities are adsorbed by the filtration layer, and the filtered water flows from the filter nozzle to the outlet. The cleaning of the filter can be done by backwash. At this time, the water flows reversely from the top of the filter nozzle, causing turbulence disturbances in the filter layer and the adsorbed impurities are released and discharged through the discharge valve. The backwashing process can be automatically completed based on the pressure difference of the inlet and outlet or timing.

Name	16 "	20 "	24 "	30 "	36 "	42 "	48 "	60 "	
Body dia.(mm)	400	500	600	750	900	1050	1200	1500	
Inlet/outlet dia.(mm)	40	50	50	80	80	80	100	100	
Flow rate(m3/h)	6-10	10-18	15-25	15-35	30-50	45-65	50-90	80-100	
Sand bed thickness(mm)	Quartz sand		400	400	400	400	270	300	300
Sand bed volume(L)	65	100	140	220	318	320	452	707	
Sand bed weight(kg)	20	150	180	280	400	360	560	1100	
Net weigh(kg)	55	75	95	155	200	245	285	400	
Vessel volume(L)	90	150	275	372	535	716	926	1465	

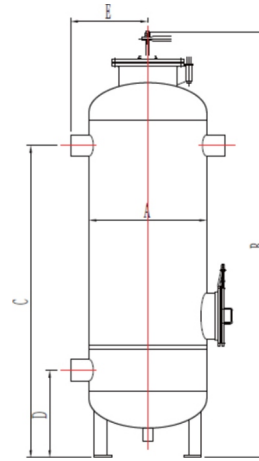

Figure1	16"	20"	24"
A	390	480	610
B	1185	1293	1287
C	876	880	880
D	185	180	180
E	219	266	331

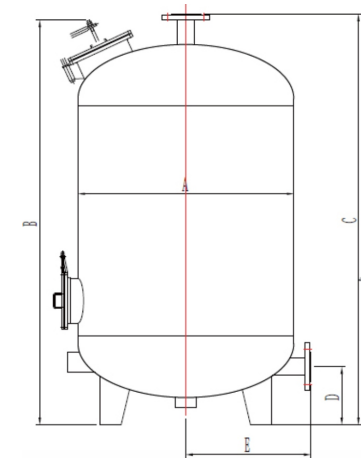
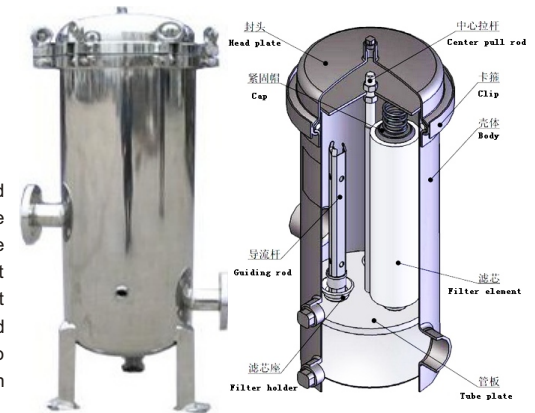

Figure2	30 "	36 "	42 "	48 "	60 "
A	750	900	1050	1200	1500
B	1231	1219	1219	1186	1370
C	1100	1100	1100	1100	1265
D	196	196	340	365	400
E	430	505	585	660	814

PRECISION FILTER

Precision filter is also called security guard filter which generally set before the pressure vessel to remove fine particles with the turbidity more than 1 degree so as to meet the requirements of water in subsequent processes. Sometimes, it also set at the end of the whole water treatment system to prevent the fine particles (such as a broken resin) to flow into the water.



TECHNICAL PARAMETER

Model	Spec	Flow t/h	Inlet Height mm	Outlet Height mm	Drainage Valve Height mm	Size of Internal Rod inch	Body Diameter	Total Height mm
JXY3-10	10×3	1.5	250	70	40.130	1	180	400
JXY5-10	10×5	2.5	250	70	40.130	1	200	400
JXY3-20	20×3	3	300	70	40.130	1.2	200	610
JXY5-20	20×5	5	300	70	40.130	1.2	200	610
JXY7-20	20×7	7	300	70	40.140	1.5	250	610
JXY9-20	20×9	9	300	70	40.140	1.5	300	610
JXY12-20	20×12	12	300	70	40.130	2	350	610
JXY5-30	30×5	7.5	500	70	40.130	1.5	220	900
JXY7-30	30×7	10.5	500	70	40.140	1.5	250	900
JXY9-30	30×9	13.5	500	70	40.140	2	300	900
JXY12-30	30×12	18	500	70	40.140	2	350	900
JXY5-40	40×5	10	550	90	40.130	1.5	220	1150
JXY7-40	40×7	14	550	90	40.140	2	250	1150
JXY9-40	40×9	18	550	90	40.140	2	300	1150
JXY12-40	40×12	24	550	90	40.140	2.5	350	1150

ADVANTAGE



Sealing structure is simple and reliable



Higher filtration efficiency



High filter precision and uniform filtration aperture



Lower filter resistance, great flux, strong capacity and long service life



With high purity, the cartridge material has no pollution to the filter medium



Easy to clean, filter cartridge can be replace

APPLICATION

Widely used in the pretreatment and terminal processing of electronic industry, pharmaceutical industry, drinking water, food, beverage, beer and other industry.

SIGLE BAG FILTER



High pressure type



Lifting lug flange type



Low pressure type

WORKING PRINCIPLE

The bag filter is supported by the stainless steel mesh inside. The liquid flows into the chamber via inlet and go through the filter bag. The impurities will be blocked in th filter bag. The filter bag can be reused repeatedly after washing or cleaning. And also the filter bag is easy to change. With no material consumption, this filter has low operation cost.

TECHNICAL PARAMETER

Model	Filtering area (m²)	Max flow (t/h)	Working pressure (Mpa)	Volume (L)	Inlet / outlet connection	Overall height (mm)	Housing height (mm)
JXB-1	0.25	20	0.5	8	DN40	220	568
JXB-2	0.5	40	0.5	17	DN50	220	960
JXB-3	0.20	10	0.5	4	DN32	159	568

APPLICATION

Chemical industry,pharmacy,automobile industry,light industry,food industry,electroplating industry,etc.

ADVANTAGES

1. High Capacity with samll size;
2. Labor saving: easy to replace filter bay, no need to clean the filter;
3. Cost saving: filter bag can be used repeatedly after cleaning;
4. High precision: can be reached 0.5µm;
5. Low leakage risk which ensures high filtering quality;
6. Energy saving:high working pressure, low pressure loss and low operation cost;
7. Wide application, flexible use and various installation method for choice.

REMARK

1. Max capacity is the reference value based on water test, the actual value can be different because of liquid viscosity, solid content and pressure difference;
2. The material can be carbon steel, ss304 and ss316L;
3. Ring's material can be customized per customer requirement to meet the material needed to be filtered;
4. The lock method can be clamp type, hasp type and lifting lug type.

TECHNICAL PARAMETER

Model	Bag Qty	Filtering area (m ²)	Max flow (t/h)	Inlet / outlet connection	Working pressure (Mpa)	Housing Dia (mm)	Overal heigh (mm)	Housing height (mm)
JXB-2	2	1	70	DN50	0.5	456	1572	1144
JXB-3	3	1.5	105	DN80	0.5	508	1592	1190
JXB-4	4	2	140	DN100	0.5	558	1632	1244
JXB-5	5	2.5	175	DN150	0.5	608	1788	1254
JXB-6	6	3	210	DN150	0.5	658	1854	1300
JXB-7	7	3.5	245	DN150	0.5	710	1875	1340
JXB-8	8	4	280	DN150	0.5	760	1922	1404
JXB-10	10	5	350	DN200	0.5	910	2004	1430
JXB-12	12	6	420	DN200	0.5	962	2064	1460
JXB-14	14	7	490	DN200	0.5	1012	2124	1490
JXB-16	16	8	560	DN250	0.5	1112	2146	1512
JXB-18	18	9	630	DN250	0.5	1162	2225	1595
JXB-20	20	11	700	DN250	0.5	1212	2280	1640
JXB-22	22	10	770	DN250	0.5	1366	2320	1694
JXB-24	24	12	840	DN300	0.5	1416	2358	1748

APPLICATION

Chemical industry, pharmacy, automobile industry, light industry, food industry, electroplating industry, etc.

INLET / OUTLET TYPE

1. Side-in & bottom-out;
2. Side-in & side-out;
3. Bottom-in & bottom-out

OPENING TYPE

lifting lug, rocker arm and quick open.

ADVANTAGES

It not only has all the advatage of single bag filter, but also suitable for customers who need to replace the filter bag after long time using.

REMARK

1. Max capacity is the reference value based on water test, the actual value can be different because of liquid viscosity, solid content and pressure difference;
2. The material can be carbon steel, ss304 and ss316L;
3. Ring's material can be customized per customer requirement to meet the material needed to be filtered;
4. The lock method can be clamp type, hasp type and lifting lug type.

MULTI BAG FILTER



Standard type

Rocker arm type

WORKING PRINCIPLE

The bag filte is supported by the stainless steel mesh inside. The liquid flows into the chamber via inlet and go through the filter bag. The impurities will be blocked in the filter bag. The filter bag can be reused repeatedly after washing or cleaning. And also the filter bag is easy to change. With no material consumption, this filter has low operation cost.

JACKETED BAG FILTER

PRODUCT INTRODUCTION

Jacketed bag filter has double layers. There is an external layer outside the housing. And with an inlet and an outlet is equipped on the external layer, steam, water and conduction oil can be introduced into it. By this way, this filter can keep or increase the liquid temperature in the vessel so that to protect liquid from crystallization or solidification caused by temperature dropping and improve the filter speed of viscous liquid. And it also can meet the temperature requirement in the next process. The jacketed bag filter can be customized per customer's working condition. The working process and advantage is the same as single bag and multi bag filter.



APPLICATION

Pre-filtration or ultra-filtration in chemical industry, food & beverage industry and pharmaceutical industry. It can realize steam heating or condensing cooling for viscous material or the material that need thermal insulation.

TECHNICAL PARAMETER

Model	Bag Qty	Filtering area (m ²)	Max flow (t/h)	Inlet / outlet connection	Heating Inlet / outlet	Working pressure (Mpa)	Housing Dia (mm)	Overall height (mm)	Housing height (mm)
JXB-2	2	1	70	DN50	Dn25	0.5	456	1572	1144
JXB-3	3	1.5	105	DN80	Dn25	0.5	508	1592	1190
JXB-4	4	2	140	DN100	Dn25	0.5	558	1632	1244
JXB-5	5	2.5	175	DN150	Dn25	0.5	608	1788	1254
JXB-6	6	3	210	DN150	Dn25	0.5	658	1854	1300
JXB-7	7	3.5	245	DN150	Dn25	0.5	710	1875	1340
JXB-8	8	4	280	DN150	Dn25	0.5	760	1922	1404
JXB-10	10	5	350	DN200	Dn32	0.5	910	2004	1430
JXB-12	12	6	420	DN200	Dn32	0.5	962	2064	1460
JXB-14	14	7	490	DN200	Dn32	0.5	1012	2124	1490
JXB-16	16	8	560	DN250	Dn32	0.5	1112	2146	1512
JXB-18	18	9	630	DN250	Dn32	0.5	1162	2225	1595
JXB-20	20	11	700	DN250	Dn32	0.5	1212	2280	1640
JXB-22	22	10	770	DN250	Dn32	0.5	1366	2320	1694
JXB-24	24	12	840	DN300	Dn32	0.5	1416	2358	1748

SOLIDS AND LIQUID SEPARATOR

This equipment can effectively reduce the suspended matter concentration in the wastewater, so as to reduce the treatment load in the subsequent procedure. Meanwhile, it also can recycle useful substances in the wastewater.



WORKING PRINCIPLE

The main body of the solids and liquid separator (spiral type) is the wedge wire stainless steel sieve bend or flat screen. When the waste water is distributed evenly on the inclined screen, the solid will be intercepted and the filtered water will flow out through the slot of the screen. At the same time, the solid will be pushed to the bottom of the screen and discharged out by the hydraulic power. The reason that the solid will be intercepted is that the surface of the screen has small and smooth slot and the back side has large slot. After solid-liquid separation, the solid will be transferred to the spiral press which can dehydrate the solid. After dehydration, the water content can be lowered to 40%.

EQUIPMENT STRUCTURE

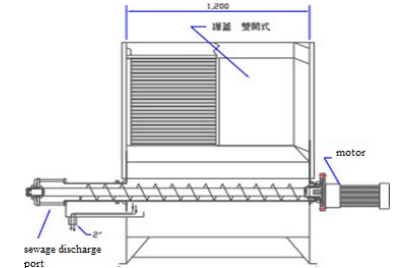
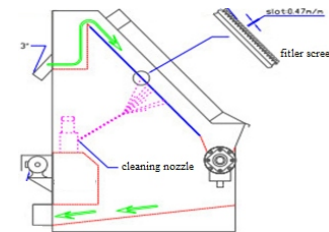

TECHNICAL PARAMETER

JXF-1Z(70)	JXF-1Z(120)	JXF-1Z(150)
Treatment capacity: 10-20ton	Treatment capacity: 20-40ton	Treatment capacity: 30-50ton
Power: submersible pump: 1.5kw, lift: 6m	Power: submersible pump: 2.2kw, lift: 8m	Power: submersible pump: 3.0kw, lift: 6m
press: 2.2kw	press: 3.0kw	press: 4.0kw
Screen cleaning machine: 25kw	Screen cleaning machine: 50kw	Screen cleaning machine: 50kw
Motor: 550w	Motor: 750w	Motor: 750w
Agitator: 2.2kw	Agitator: 2.2kw	Agitator: 2.2kw

Remark: Some solids will precipitate at the bottom of the water tank and cause high concentration, so this machine must be equipped with agitator to even the concentration or the screen can't load that much.

FEATURE

1. Using water gravity for operation, no energy consumption; 2. Using water filter net technology and with 0.3-0.5mm slot, this equipment has high treatment capacity and the most thoroughly filtration; 3. Uneasy blocking and easy cleaning; 4. Made of stainless steel, this machine has high mechanical strength, long using life and no distortion features; 5. Auto-detection, the machine will be started when reaching the water level . Full automatic of filtering , pressing and screen cleaning; 6. Gear type reverse washing mechanism without any consumption.

APPLICATION

1. To remove the solid substance such as suspended matter, floater and precipitate in the waste water treatment of slaughter, leather, paper, sugar, wine-making, food processing, textile, printing and dyeing, petrochemical industry; 2. To recycle useful material such as fiber in paper, alcohol, starch and food industry; 3. Pretreatment of sludge and channel cleanout.

DIATOMITE FILTER

Beer filtration through candle diatomaceous earth filter is the most common solution of a filtration in a microbrewery of medium and large sizes. Beverage filtration is done through driftwood filter means on the vertical filter candles. Candle filter is characterized by high filtration efficiency. The most widely used filter medium is diatomaceous earth. Depending on the composition of the filter layer different degrees of purity and flow of filtered liquid can be achieved. Ongoing diatomaceous earth dosage by a dosing pump keeps the filter still enough permeable. This allows to achieve high-capacity performance. Cleaning (regeneration) of the filter is very easy and fast, without disassembling the pressured vessel. The filter is fitted as standard with the sight glass at the inlet and outlet. It can be equipped with various degrees of automation. The filter is a mobile device mainly on travel wheels.



DIATOMITE FILTRATION ON CANDLE FILTERS

The filter material (diatomaceous earth) is sluicing on a supporting structure of the filter candle. These are made of stainless steel wire with trapezoidal special cross-section design, ensuring high deformation resistance and durability of these carriers. Hence result a high filtration efficiency, the possibility of using filter for coarse filtration and sharp filtration before secondary micro-filtration.



TECHNICAL PARAMETER

Filtering area(m2)	Housing diameter(mm)	Working pressure(Pa)	Working temperature(°C)	Filtering precision(um)
2-120	Φ219、Φ300、 Φ400、Φ500、 Φ600、Φ800、 Φ1000、Φ1200、 Φ1400、Φ1600、 Φ1800、Φ2000	0.4	120	1、5、10、 15、25、40、 50、65、75、 80、100、 120 ...

ADVANTAGES

1. This machine comprises: pump, tank, screen pipe, observation mirror, vent valve, sight glass, pipe and valve. All the material which directly contact with the liquid adopts 304 stainless steel. All the closure head adopts flange type.
2. This vertical diatomite feature has obvious advantage than cotton cake filter and horizontal filter: Save 95% energy; Reduce 90% of wine loss; Save 2/3 of cost; Save 3/4 of workers
3. Shorter time of diatomite adhesion, the liquid can be clear in one minute. Fast and convenient.
4. Low using cost: the diatomite which adhered on the screen pipe will be automatically fall off when changing the diatomite. And the diatomite can be discharged by open the valve, no need to disassemble the filter. The screen pipe can be washed repeatedly without replacement.
5. The wine or beverage filtered by this machine is clear and remains the original flavor and has the feature of non-toxic, no suspended solids, no precipitation.
6. Good filtering performance. The diatomite, supported by the screen pipe, will formed a filtering layer on the surface which will not deformed by the pipe pressure or electric pressure.
7. High filtering efficiency. When filtering, each screen pipe has separated passage. So it has low filtering resistance and the consumption of the diatomite is less.

APPLICATION

This filter is widely used in liquor, wine, low-alcohol wine, rice wine, soy sauce, vinegar, and beverage industries. The clarify degree after filtering can reach 99.8%.

SIEVE BEND SCREEN FILTER

Sieve Bend Screens are ideal for sizing and dewatering applications to remove solids from liquids, or in solid/solid separation for dry feed situations.



Sieve Bend Screens can be manufactured in a variety of widths, arc lengths, apertures or wedge wires to suit the flow rate and material being separated. Although most applications require Static Sieve Bends, "Cross Flow", "With Flow" and "Vibrating" Sieve Bends can also be manufactured.

WORKING PRINCIPLE

The feed slurry is directed vertically and tangentially over the full width of the upper screen surface. The slurry flows down the concave surface at right angles to the openings between wedge profiled wires. Due to the drag on the slurry passing over the wedge wire, a thin layer on the underside is deflected and passes out between the wires. The fact that the size of particle passing through the screen is always smaller than the opening, gives the screen good non-clogging properties.

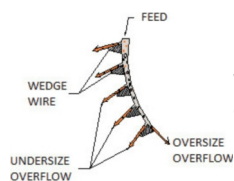

In a typical feed situation the leading edge of the wedge wire removes the water and fine particles through the screen up to the cut point size, as the oversized particles move across the top of the screen. Static Sieve Bends require little or no maintenance in their operation and need only small head heights to operate.

FEATURES & ADVANTAGE

1. Working with the water gravity, no energy consumption;
2. High water treatment capacity;
3. Not easy to be blocked and easy to clean;
4. Using stainless steel, it has high mechanical strength and long life.

APPLICATION

1. To remove the solid substance such as suspended matter, floater and precipitate in the waste water treatment of slaughter, leather, paper, sugar, wine-making, food processing, textile, printing and dyeing, petrochemical industry;
2. To recycle useful material such as fiber in paper, alcohol, starch and food industry;
3. Pretreatment of sludge and channel cleanout.

TECHNICAL PARAMETER

Model	Effective Screen Width x Radius (mm) x Angle	Approx Assembly Dimensions Width x Depth x Height (mm)	Approx. Mass of Assembly (kg)
JXR600	600 x 1018 x 45	786 x 900 x 1200	140
JXR900	900 x 1018 x 45	1086 x 900 x 1200	180
JXR1200	1200 x 1018 x 45	1386 x 900 x 1200	225
JXR1500	1500 x 1018 x 45	1686 x 900 x 1200	265
JXR900	900 x 2036 x 45	1086 x 1400 x 2100	325
JXR1200	1200 x 2036 x 45	1386 x 1400 x 2100	395
JXR1500	1500 x 2036 x 45	1686 x 1400 x 2100	455
JXR1800	1800 x 2036 x 45	2040 x 1400 x 2100	755
JXR2100	2100 x 2036 x 45	2340 x 1400 x 2100	835
JXR2400	2400 x 2036 x 45	2640 x 1400 x 2100	920
JXR2400	2400 x 2036 x 45	2640 x 1400 x 2100	920
JXR2700	2700 x 2036 x 45	2990 x 1400 x 2100	1,035
JXR3000	3000 x 2036 x 45	3290 x 1400 x 2100	1,120

INNER SCRAPER TYPE SELF-CLEANING FILTER

Liquid enters through the water inlet and flows up to bottom and then flow out through the surface of the filter elements. When the impurities on the surface of the filter element accumulates to a certain amount, the scraper which is driven by electric machinery and equipped with correctors will rotates closely on the filter elements to scrap off the impurities. Then the impurities will be collected in collection chamber. when it collected to a certain amount, the automatic drain valve opens and drain out the liquid containing high concentration of impurities. The liquid after filtration would be recycled or discharged.

Ps: Inner-scraper: scraper is inside the filtering element; outer-scraper: scraper is outside the filtering element.

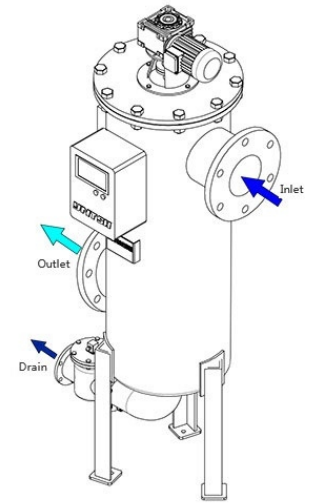
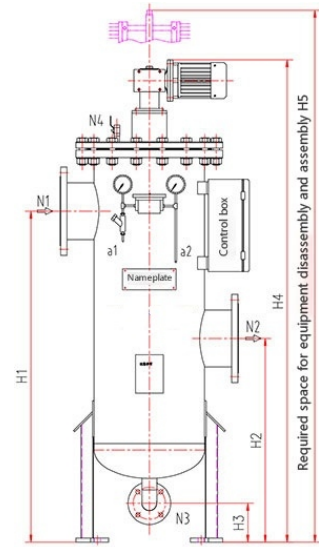
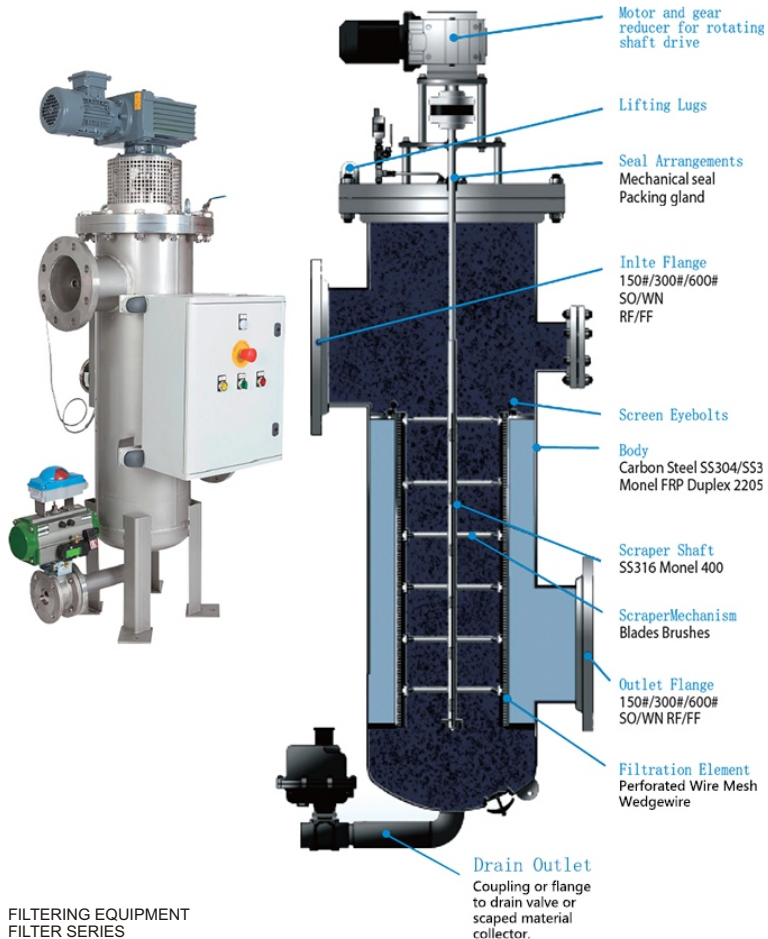

MAJOR COMPONENTS

1. Drive motor, differential pressure controller, differential switches, indicator light, valves; alarms, timers and display screens as option.
2. Circuit breaker for overload protection.
3. PLC-based control system for control the time of scraper and sewage discharge.
4. Differential pressure controller protection and monitoring system.
5. Drain valve driving: electric/pneumatic.
6. Pre-installed and tested for easy installation.

Model	S2-273	S2-325	S2-426	S2-530	S2-630	S2-720	S2-820	S2-920
Pipe dia (mm)	80	100	200	250	300	350	400	450
Flow rate (m3/h)	50	150	300	500	700	1100	1500	2000
Filter area (m2)	0.25	0.35	0.66	1.0	1.2	1.5	1.8	2
Drain valve DN (mm)	25	25	50	50	80	80	80	80
Motor power (kw)	0.55	0.55	0.55	0.55	0.75	0.75	0.75	0.75

SCRAPER SELF-CLEANING FILTER

Scraper self-cleaning filter, different from backwashing self-cleaning water filter, is not only used for water filtration, but also widely used in the self-cleaning filtering of solvents, acid alkali, polymer, coating adhesive materials and so on. It has higher efficiency and high precision with range of 30-1500 microns. It can filter liquid viscosity up to 800000 centipoises. It is widely applied in water treatment, petrochemical, metallurgy, electric power, chemical, paint, printing ink, paper, food and beverage, pharmaceutical, metal processing industries and etc.



Scraper filter which is fully automatic operation, high filtration precision, stable and reliable performance is an efficiency choice of replacing traditional manual filter or use dumping type material filter. In many areas it can replace the traditional cartridge filters, bag filters, basket filters, vibrating screen filters.



Filter body	CS/SS304/SS316L resistant to acid alkali corrosion SS316L performance better
Filter screen	SS304/SS316L
Drive Shaft seal	PTFE Teflon suitable for all kinds of solvent, acid or alkali liquid, the highest temperature 230°C
Sealing ring	NBR acrylic rubber, applicable to most of the neutral and oil liquid, the highest temperature 120°C
VITON fluorine rubber	Resistant to acid and alkaline liquid and the majority of the solvent, the highest temperature 230°C
Scraper	SF type is super wear resistant composite material, SS type is Wear resistant stainless steel blade
foot support	SS304

WORKING PRINCIPLE

Scraper self-cleaning filter's operation principle is very simple: Install the filter screen ② in a stainless steel cylindrical shell ①. When unfiltered liquid flows into the shell from the inlet ③, solid impurities were leached and deposited on the inner surface of the screen. filtered liquid flows out from the outlet ④. When filter screen need cleaning (depending on the time, pressure differential, or manually choose), a clean dish tightened with spring scrapes the mesh inside surface back and forth constantly and removes the deposition of solid material. When the debris is separated from gap of the filter screen, wash dish will send the dirt into the bottom of the shell ⑥ and discharged through the flow channel ⑦.

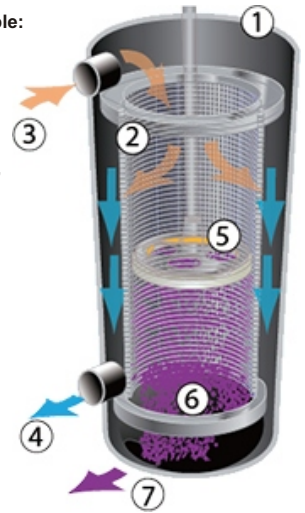

Pneumatic cleaning plate drives through air pressure (60-80 psi @ 5 CFM). S-01 and S-02 filter's main characteristic is that they can be driven by single cylinder or double cylinder. The smaller S-01 model is only equipped with a cylinder.

BRUSH TYPE AUTOMATIC SELF CLEANING FILTER

Brush type automatic self cleaning filter is a kind of filter that is suitable for bad environment, it can be equipped with 3500 microns - 50 micron mesh and 8-36 pipeline diameter for different using requirements. The cleaning process is started by a differential pressure switch which is monitoring the different pressure of inlet and outlet, usually the default value of pressure difference switch is 0.5 bar (7psi). With advantages of continuously fluid flow, safety operation, simple maintenance, this filter is widely used in all industries area.



WORKING PRINCIPLE

When the differential pressure of inlet and outlet reaches the preset value, the filter will start the self-cleaning process. The whole self-cleaning process contains two steps: open the drain valve on the end cover of the filter; the two stainless steel brushes in the filter mesh is driven by motor, then the impurities which is captured by filter mesh will be brushed down by the steel brush and will be discharged from the drain valve. The whole cleaning process takes about 15 to 60 seconds. During this time, the filtration system does not stop and the whole operation process is controlled by a control box.

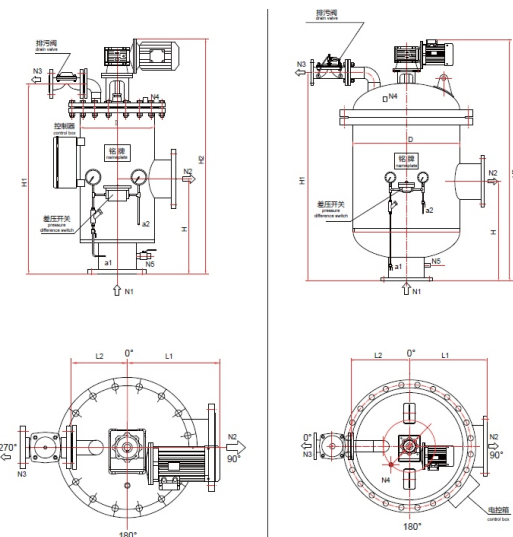

FEATURES AND ADVANTAGES

- 1. Continuously water supply:** water consumption in the cleaning process is less, which is nearly 5% of filter water yield, the flushing time is 2 ~ 15 seconds.
- 2. High filtration precision:** the filtering precision can reach 20 microns.
- Large filtering area:** the effective filtering area of standard filter screen is 7 ~ 40 times of the inlet area.
- 3. Reliable cleaning types:** there are many kinds of control mode (manual, differential pressure, timing, PLC program logic control and other control mode for choices).
- Simple and economy installation:** diversified structure, suitable for installation in all kinds of site conditions, and does not affect the running effect.
- 4. Long service life:** Normally the working life will be more than 10 years, according to the requirements, the stainless steel mesh can be easily replaced by different specifications.



GENERAL PARAMETERS

Operation flow rate : 20-5000m³/h; **Min working pressure :** 2bar; **Max working pressure :** 10bar/150psi;
Filtering area : 3000cm²-20000cm²; **Inlet / outlet diameter :** 50/80/100/150/200/250/300/350/400 /500/600/800mm;
Max working temperature : 50°C

CLEANING PARAMETERS

Drain valve Size:25mm/50mm/80mm; **Cleaning time:**30-60S; **Cleaning water consumption(every time):**≤ 1%.

MATERIAL

Filter body : Carbon steel Epoxy resin coating; stainless steel 316 304;
Filter mesh : Stainless steel 316L Wedge wire cartridge ; Stainless steel 316L woven wire cartridge;
Clean body (interior) : Stainless steel 304,316L, POM; **Drain valve :** Cast iron, epoxy resin coating; 304,316L;
Seal ring : synthetic rubber, PTFE.

Model	JX01-219	JX01-273	JX01-325	JX01-426	JX01-530	JX01-630	JX01-720	JX01-820	JX01-920
Pipe diameter(mm)	50	80	100	200	250	300	350	400	450
Filter flowrate(m ³ /h)	20	50	150	300	500	700	1100	1500	2000
Filtrationarea(m ²)	0.27	0.25	0.35	0.66	1.6	0.85	1.3	1.4	1.8
Drain valve DN(mm)	25	25	25	50	50	80	80	80	80
Motor power	0.55	0.55	0.55	0.55	0.55	0.75	0.75	0.75	0.75

APPLICATION FIELD OF WEDGE FILTER

Water and sewage / Pulp and paper / Chemical / Petrochemical industry / Steel / Nonferrous metal / Plastic extrusion processing / Machine coolant filtration / Construction field

AUTOMATIC BACKWASH FILTER

This filter provides fully automatic backwashing cleaning operations, and it can continuously separate impurities from water and other liquids. The maintenance and operation of filter is very simple, even in the severe operating conditions it also can continue to keep running in a good condition.

XF-F series filter can be equipped with different amount of elements to provide maximum filtering area in each filter housing. This makes the filter to have smallest pressure loss when working.

The pressure design of filter body is usually based on the chemical pipeline filter and steel pressure vessel design standards. The filter also can adapt to the special requirements of other design criteria. Filter main body has the materials such as carbon steel, stainless steel, and duplex phase steel and etc. At the same time, we also can provide special materials such as titanium, pure nickel and etc.



WORKING PRINCIPLE

The water which needs to be filtered flows into the shell through the lower bottom of the filter and enters the lumen of the filter element through the rotary table from bottom to top and be drained out through the filter element. The filtered clean water flows out from the upper outlet of the filter. Solid impurities are trapped in the inner side of the filter element. No need of cutting off the water flow when the filter is on backwashing process. Motor drives filter wheel rotating and at the same time the drain valve was opened. Each filter element will be backwashed by the filtered clean water in turns. The pressure difference between the water pressure in filter and the atmospheric pressure can make filtration liquid flows reversely so that the intercept impurity on inner face of the filter element can be removed. After the wheel rotates a round, backwashing process is over. Then backwashing valve closed and drive motor stops.

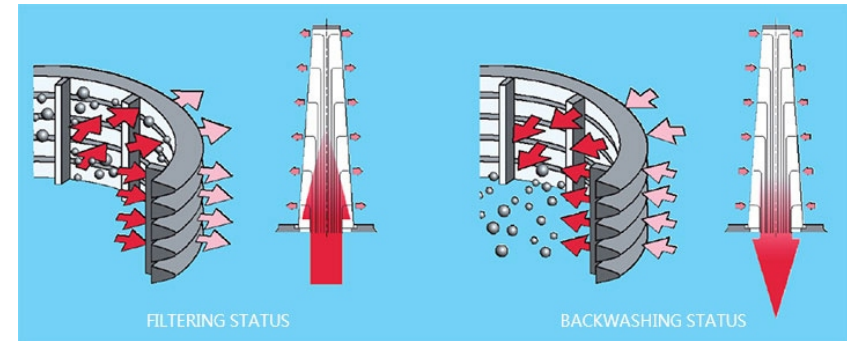

PRODUCT FEATURES

Flow rate	1-5000M3/H
Filter precision	25-3000μm
Working pressure	0-10.0Mpa
Valve	Motor or Pneumatic
Filtration standard	GB150,HG/T21637
Filter element material	304 316 Hastelloy
Valve material	CS 304 316 Hastelloy
Seal material	Buna-N EPDM Fluorous rubber

AUTOMATIC SELF-CLEANING FILTER

ADVANTAGE

1. Control by sensing pressure difference, when the impurities gathered, once the pressure differential exceeds the set value (1 Bar), the control switch turns on to start cleaning axis;
2. Back flushing can be manual or automatic control;
3. Impurities flow out through backwashing arm to backwashing outlet;
4. Filtration accuracy: 25~200 micron; 5. Solid content: < 200ppm.
6. Flow rate reach up to 4500M3/H.

WORKING PRINCIPLE

When liquid with impurities flows into the bottom of the filter casing, the liquid flow rate will slow down, and the liquid will flow upward in direction of 90°. The impurities which is been filtered down will be stopped in the shell, and the cleaning fluid will constantly flow outside of isolation elements, then finally flowed out from the outlet.

Back flushing process is completed by the difference between pipeline pressure and atmospheric pressure. A hollow cleaning device extends the length of the whole element; it rotates slowly inside the filter, and then discharge impurities out from drain valve. The end face of cleaning device is very close to filter element, its opening and impurity collector is of the same height. The impurity collector is made up of circle round and vertical pipeline tubes. In the whole countercurrent washing cycle, the main fluid will not be stopped and filtration process is going on.

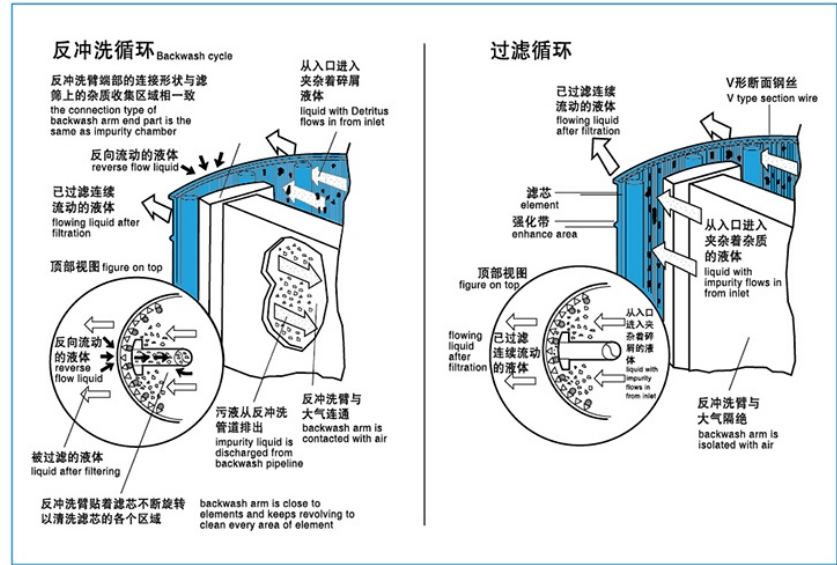
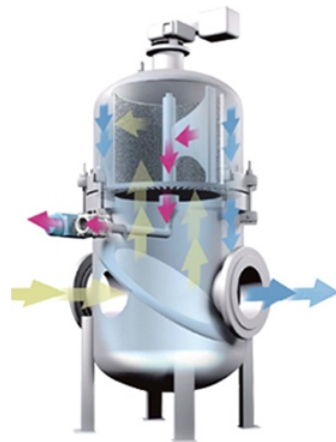

TYPICAL APPLICATIONS

Automatic self-cleaning filter can be used in almost all industrial area, including water supply, water disgusting, and the smell of salt water system, used for cooling, processing, fire protection services and so on. This ensures the cycle of water resources and saves cost.

Processing industry : protection of heat exchanger, the valve and water spray nozzle, pump and valve.

Electric power industry : protection of heat exchangers, pipeline pumps, waste water recycling system, etc.

Pulp processing industry : Remove fiber from water and prevent clogging nozzle. In the process of circulation, separate bark and chip.

Sewage/waste and water : the secondary filter processing of sewage, filtering the effluent in step two, then provide clean water for plants.

Metal processing industry : Provide large clean water for quenching, derusting, furnace, etc.

OUTER-SCRAPER SELF-CLEANING FILTER

FEATURES

1. With leading outer-scraper filter type, this filter extends the filtration time under same filter area and reduces the waste of material; 2. Adaptive adjustment of miscellaneous equipment ensures that the filter will not be affected by the wear when working for a long time; 3. Filter elements are made by mold, the roundness deviation do not exceed 0.5mm to ensure the scraper will be completely fit to the elements; 4. Humanization design: the drain valve would open just when impurity is collected to a certain amount after cleaning several times so as to reduce material waste.

AUTOMATIC CLEANING FILTER SCREEN

It uses the speed reducer to drive the cyclotron scraper and clean the dirt attached on the mesh to keep the cartridge filtration function. The unique clear design keeps flowing unblocked forever. Precision scraper pressure and angle design ensure zero damage to mesh in a short time and it is durable and can be changed quickly.

WEDGE FILTER SCREEN WORKING PRESSURE OPTION

1. Wedge filter screen 1mm is suitable for working pressure lower than 16kg/cm²;
2. Wedge filter screen 1.5mm is suitable for working pressure lower than 16-30kg/cm²;
3. Wedge filter screen 1.8mm is suitable for working pressure higher than 30kg/cm² (standard for Φ85mm).

STANDARD SIZE

1. Filter screen OD: 85mm , 168mm , 268mm ;
2. Standard filter screen length 600mm.



INTERNALLY FED ROTARY DRUM SCREEN

PRODUCT INTRODUCTION & WORKING PRINCIPLE

The Internally fed rotary drum screen is suitable for solid-liquid separation of industrial wastewater, can remove the suspended particles which are greater than 0.2 mm. Wastewater flows evenly into the rotating drum, sewage discharges from the other side conducted by rotating spiral, then the filtered water discharges from the slot of screen drum.

FEATURES

1. Well-distributed water increase capacity;
2. Simple structure, stable running, easy maintenance;
3. Chain transmission ensures efficiency;
4. Back-flushing prevents filter clogging;
5. Spill-proof plates on sides prevent water splashing.



TECHNICAL PARAMETER

Model	Drum diameter (mm)	Slot Size (mm)	Removal rate		Size (mm)
			Particle >0.75mm	Particle >0.37mm	
JXN-600	600	0.2-2	95%	55%	2450x1000x960
JXN-800	800				3000x1200x1200
JXN-1000	1000				3400x1350x1250
JXN-1200	1200				3500x1850x1450
JXN-1500	1500				3650x1800x1880

*Above parameters only for reference, customized available for detailed requirements

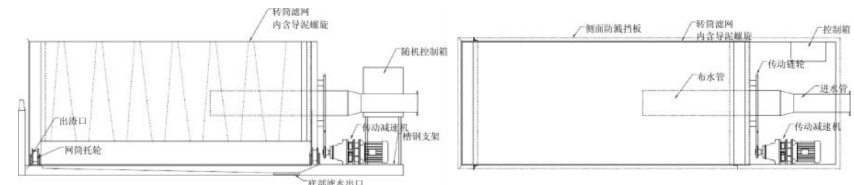

EXTERNALLY FED ROTARY DRUM FILTER



RANGE OF APPLICATION

The externally fed rotary drum filter can remove the tiny particles with the diameter larger than 0.25mm in the water. Application: sewage treatment of papermaking, tanning, slaughtering, wine and food, chemical fiber industry, textile industry and etc.

WORKING PRINCIPLE

At speed regulating motor through a speed reducer drive reseau cylinder, sewage enters into the tank through the inlet valve and rises above the filtering waterline through the buffer box clapboard. Then the purified water enters into bottom of the tube through the slot of the grid mesh and flows out. With this procedure, the grid mesh also has been cleaned at the same time. And during this time, the impurities and organic matters whose size is greater than the slot of the grid mesh is blocked and transferred into the other side of the grid mesh. Finally, the blocked impurities and organic matters is discharged by the unloader into the slag hopper. After processing, the sewage moisture content is 30% ~ 50% lower than the original water equipment 30%~50%. By filtering sewage flow out of the water tank and is discharged through drain.

ADVANTAGES

1. Material: stainless steel, corrosion resistance, compact structure and easy installation;
2. With inverted trapezoidal section, the grid makes the slag not easy to jams mesh filters;
3. Adopted control motor, the externally fed rotary drum filter can maintain the best working condition according to the water flow;
4. Special flusher device can brush away small amount of impurity on the surface of the grid mesh.

TECHNICAL PARAMETER

Model	Net tube size D*L	Rotating speed r/min	Power KW	Backwash water	
				Flow m³/h	Pressure Mpa
TPLW-600	600*1000	4-20r/min	0.75	2.5-3	≥0.4
TPLW-800	800*1200		1.1	2.5-3	≥0.4
TPLW-1000	1000*1400		1.5	3.5-4	≥0.4
TPLW-1200A	1200*1500		1.5	3.5-4	≥0.4
TPLW-1200B	1200*2000		2.2	4.5-5	≥0.4
TPLW-1500	1500*2000		3	4.5-5	≥0.4

1. Water storage bin
2. Frame
3. rotary drum
4. Slag falling plate
5. Inspection door
6. Reducing motor
7. Backwash water inlet

SPIRAL ROTARY DRUM SCREEN

Spiral Rotary Drum Screens are integrated machines consisting of a drum screen, screw conveyor and compactor. Effluent enters the screen drum and solids are captured. When the drum rotates the solids fall into the spiral conveyor. The spiral feeds the screenings into a compactor where they are compressed and disposed. Screen water continues downstream. The rotating screen drum ensures screen does not blind. Filtration rates of between 1-7 mm are available, alongside flow rates of up to 7600 m3/h.

CONSTRUCTION

Housing constructed out of high quality 304 stainless steel to ensure years of trouble free operation. Spiral manufactured out of carbon steel with optional 304 stainless steel construction. Nylon cleaning brushes bolted to spiral. Spiral Rotary Drum Screens can be supplied for direct installation into a channel or as a complete package inside a stainless steel tank with or without the option of a bypass rake screen. Continuous bagging systems are available to receive screenings and abate odour, the screenings can then be sealed without any personal contact. Options for 316 Stainless steel area available.

OPERATION

Solids within the incoming flow will enter into the drum screen and progressively collect onto the screen mesh and cause it to gradually blind. The upstream water level will rise and at a predetermined level, the drum screen and screw conveyor will activate and rotate, immersing a clean section of the screen into the effluent. During rotation the solids or screenings will become inverted and then fall into the screw conveyor. Spray nozzles and a roller brush fixed to the periphery of the drum screen will clean away any residual solids from the mesh surface. The screenings are conveyed, compacted and dewatered and depending upon the solid properties, a volume reduction of around 40% DS or greater can be achieved prior to disposing the screenings into a skip or holding vessel.

A jet wash facility in the compaction zone will breakdown and remove faecal and other semi-solid or soluble mater and return it to the inlet flow. Additional jets can be installed in the transport zone to meet higher specifications of organic solids removal. Faecal matter washing efficiencies greater than 90% and screenings weight reduction of 50% can be achieved. The compactor and wash system can be omitted to suit requirements such as CSO applications where the screenings are returned to the downstream sewer.

ADVANTAGES

1. High quality and reliability at low cost;
2. Reduced disposal costs because of the screenings press;
3. High solids capture;
4. Easily installed onto an existing or new treatment works;
5. Non-clogging even with fibrous materials;
6. Protection of downstream plant and drains;
7. Improved Health & Safety with optional continuous bagging;
8. Enclosed drum screen;



TECHNICAL PARAMETER

Model	OA-600	OA-800	OA-1000	OA-1200	OA-1400	OA-1600	OA-1800	OA-2000		
Drum diameter	600	800	1000	1200	1400	1600	1800	2000		
Standard mesh length	650	850	1000	1200	1400	1500	1650	1850		
Outer diameter of conveying pipe	159	219	219	273	273	325	325	325		
Highest water level H3	400	520	670	820	950	1100	1250	1350		
Standard installation angle	35°									
Average channel depth H2	600 -800	700 -1000	900 -1200	1100 -1400	1200 -1600	1400 -1800	1600 -2000	1800 -2100		
Standard slag discharging height H1	1000mm									
Min.installation length A	3000	3300	3600	4000	4300	4700	5000	5300		
Max. flow capacity m3/h	slot	0.5	80	135	235	315	450	585	745	920
		1	125	215	370	505	720	950	1205	1495
		2	190	330	555	765	1095	1440	1830	2260
		3	230	400	680	935	1340	1760	2235	2755
		4	235	430	720	1010	1440	2050	2700	3340
		5	250	465	795	1105	1575	2200	2935	3600

APPLICATIONS

1. Process liquor or fluid screening;
2. Municipal waste water treatment works;
3. Industrial effluent discharges;
4. MBR Membrane pre-screening;
5. Commercial outlet discharges;
6. Storm flows;
7. Sea outfall discharges

DRUM TYPE MECHANICAL GRID

PRODUCT INTRODUCTION

The drum type mechanical grid is an equipment which can continuously and effectively remove the suspended solids in the water. It is mainly used in the pretreatment of the sewage water or the process of industrial screening. In some sewage water treatment, the sewage after treatment can remove 30%-60% of organic or non-organic suspended solids. This can reduce the treatment load of the back-end production.

APPLICATION

This equipment is widely used in food, Brewing, pharmacy, dairy products and ect. To filter the fine solids.

MAIN STRUCTURE

Drum, driving mechanism (motor reducer), unloading device, backwashing pipe, seal assembly, inspection door, frame and etc.

WORKING PRINCIPLE

Sewage or other original water flows into the drum through the internal face of the drum, then discharge at the bottom. The suspended solid then intercepted on the surface of the drum. Finally, with the rotary of the drum, the suspended solids is sent to the discharge device.



TECHNICAL PARAMETER

Type / Apply / slot	RD06/900	RD06/1200	RD06/1500	RD06/1800	RD06/2100	RD09/1200	RD09/1800	RD09/2500	
Treatment capacity(m3/h)	35-150	50-200	65-250	75-300	90-350	70-280	100-400	130-550	
Slot(mm)	1-3								
Specification	RD06/900	RD06/1200	RD06/1500	RD06/1800	RD06/2100	RD09/1200	RD09/1800	RD09/2500	
Drum size(mm)	Φ600x900	Φ600x1200	Φ600x1500	Φ600x1800	Φ600x2100	Φ900x1200	Φ900x1800	Φ900x2500	
Grid length(mm)	1900	2200	2500	2800	3100	2300	2900	3600	
Grid width(mm)	1400					1700			
Grid height(mm)	1700					2200			
Inlet pipe(mm)	Dn200	Dn250		Dn300	Dn350	Dn300	Dn350	Dn300	
Outlet pipe(mm)	Dn2500		Dn300		Dn350	Dn400	Dn350	Dn400	Dn450
Washing pipe(mm)	Dn20	Dn25		Dn32		Dn25	Dn32		
Backwashing spray nozzle number	6	8	10	12	14	8	12	16	
Washing pump flow(m3/h)	2.5	3	4	5		3	5	6	
Washing pump lift(mm)	50								
Discharge height(mm)	500					600			
Grid motor power(kw)	0.55			0.75			1.1		
Grid weight (kg)	630	820	1000	1160	1300	1200	1470	1800	

ROTARY DRUM SCREEN



PRODUCT INTRODUCTION

The technology of this equipment is called micro filtration. It is used to separate the micro suspended solid (paper fiber) out of the liquid to reach the aim of solid-liquid separation. The difference of micro filtration is that the filter media has tiny space and intercept the suspended solid by the centrifugal force of the filter drum.

This equipment is designed aiming at improving the current drum filter which is easy to be clogged, easy to be damaged, high maintainance cost and other problem.

It can be applied in any circumstance which need solid-liquid separation, such as municipal sewage treatment, paper making wastewater treatment, printing and dyeing wastewater treatment, chemical wastewater treatment and ect. It is particularly applied in papermaking wastewater treatment.

MAIN STRUCTURE AND WORKING PRINCIPLE

The drum filter is a mechanical filtering device, consisting of driving device, overflow water distributor, washing water device, filter screen, base and other parts. the filter screen is stainless steel wedge wire screen.

When the sewage water enters the overflow water distributor through the water inlet, it will stay a while to steady the flow. Then it will flow out evenly through the water outlet and distribute on the filter screen which is rotates in contrary direction. The water flow and the inner screen generate relative shear movement. The the solid will be separated and discharged from the other end of the screen and the waste water flows out from the effluent outlet at the bottom. The outside of the filter screen is configured with washing pipe which can ensure the filtering capacity of the filter screen.

FEATURES

1. Simple structure, stable operation, easy maintenance and long using life.
2. High treatment capacity, high efficiency.
Generally the recycle rate of the waste fiber is more than 80%.
3. Easy installation, less space covering, low speed operation, energy saving.
4. Continuously automatic operation, the recycled fiber concentration can reach more than 12%.

TECHNICAL PARAMETER

Item	ZG1	ZG2	ZG3	ZG4	ZG5	ZG6	ZG7	ZG8
Filter area (m2)	6	7	9	11	14	16	26	30
Filter mesh (mesh)	60-250							
Filter capacity (T/H)	50—100	80—150	100—200	120—240	150—300	170—350	240-400	300-500
Rotary speed (r/min)	4-6							
Washing water power(Mpa)	0.3							
Motor power (KW)	1.1	1.1	1.5	2.2	3	4	4	7.5
Filter screen dia.(mm)	Φ1250	Φ1250	Φ1250	Φ1500	Φ1500	Φ1500	Φ1500	Φ1780
Filter screen length(mm)	1500	1800	2300	2370	2870	3370	6000	5500
SS removal rate (%)	70-85							
COD removal rate (%)	35-50							